

STING

Flush plate for pre-wall installation systems, alunox-matt/polished

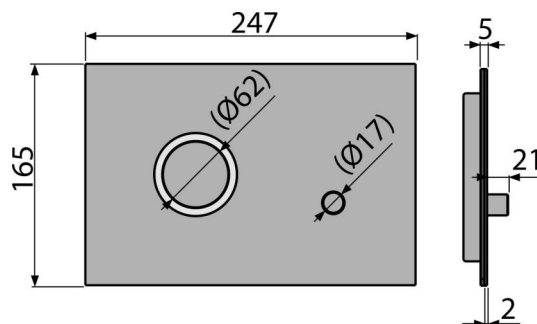

Application

For pre-wall installation systems and concealed WC cisterns

Features

- The mechanism is fully integrated into the wall
- The flush plate only slightly protrudes above the tiles
- Double-acting mechanical flushing
- Compatible for all pre-wall installation systems and cisterns for building into solid walls Alca
- Maintenance with common detergents used in the household for plumbing fixtures and bathroom accessories
- Resistant to UV rays and external influences
- Precise workmanship with laser technology
- Surface finish: alunox-mat, Anti-fingerprint with surface treatment that eliminates fingerprint smudges
- Material: anodized aluminum, stainless steel

Scope of supply

- Flush plate
- Fixing frame of the flush plate
- Threaded frame clamp 2 pcs
- Adapter kit for the control mechanism of the flush valve

Order number, Logistic information

Code	EAN	Weight (piece packing palett)	Dimensions (piece packing)	Quantity (packing palett)
STING	8595580523688	0,92 9,20 277,7 kg	255x85x175 595x245x395 mm	10 280 pcs

Warranty

2/2 years *

Technical specifications

- Operating force < 20 N