

M900KE-DN90

Connector kit for wall-hung WC with threaded rods, eccentric 25 mm, DN 90, length 215 mm, PE, white

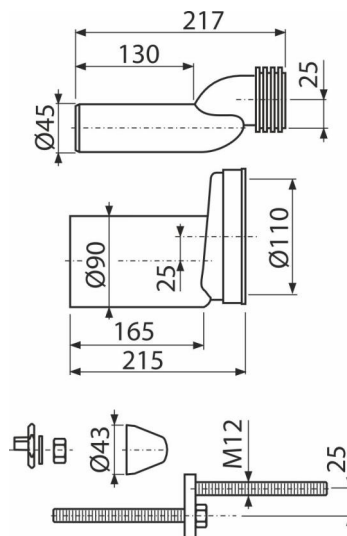
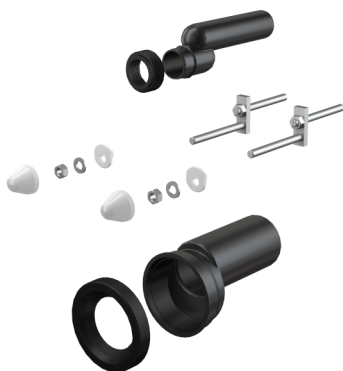

Application

For connecting water and waste to the WC – set
For pre-wall installation systems

Features

- Material: polypropylene, galvanized

Scope of supply

- Eccentric outlet fitting for wall-hung WC, polyethylene, Ø90 mm, gasket included
- WC bowl fixing set: 2× M12 threaded rods, 4× washers, 2× cover caps, 4× nuts
- Jumper for connection of wall-hung WC pan to the water supply from the cistern, polypropylene, Ø45 mm, including seals and wrapping seal

Order number, Logistic information

Code	EAN	Weight (piece packing palett)	Dimensions (piece packing)	Quantity (packing palett)
M900KE-DN90	8595580586034	1,19 17,81 304,9 kg	180×220×120 590×390×430 mm	15 240 pcs

Warranty
2/2 years *

Norms
EN 476